

# RSVR-78M

0.5A Non-Isolated, regulated DC/DC Converter

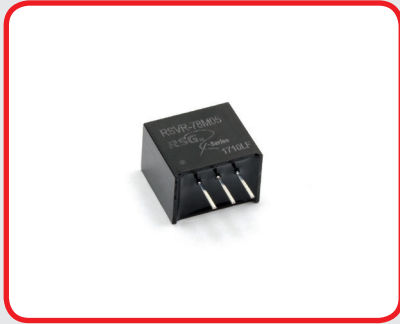

Picture similar



- 3 Pin SIL Package
- Wide Input Range
- Step-down switching
- Full SMD Technology
- Efficiency up to 97%
- Operating Temperature Range -40°C ~ +85°C
- Continuous Short Circuit Protection
- Pin-out compatible with LM78MXX three terminals positive Regulator
- Non Conductive Black Plastic Case

Output Specifications	
Voltage Accuracy	±2% max.
Output Voltage Adjustability (Trim)	–
Maximum Output Current	500mA max.
Line Regulation	±0.5% max.
Load Regulation	from 10% to 100% Load: ±0.6% max. –
Short Circuit Protection	Indefinite (Automatic Recovery)
Ripple & Noise (20 MHz bandwidth)	60mV pk-pk
Temperature Coefficient	±0.02%/°C
Transient Recovery Time	–
Transient Response Deviation	–

Input Specifications	
Voltage Range	See table
Start-up Time	–
No-Load/Full-Load Input Current	See table
Input Filter	C/L (see filter details on following pages)
Input Reflected Ripple Current	35mA pk-pk typ.
Remote ON	–
Remote OFF	–
OFF Idle Current	–
Surge Voltage (100 ms) <sup>1)</sup>	–
All Models	34VDC max.

General Specifications	
Switching Frequency	330kHz typ.
Humidity	95% rel H
Reliability Calculated MTBF	>4.5Mhrs (MIL-HDBK-217 f)
Safety Standard(s)	–

Environmental Specifications	
Operating Temperature Range	-40°C ~ +85°C (see Derating Curve)
Maximum Case Temperature	100°C
Storage Temperature	-40°C ~ +125°C
Cooling	Natural Convection
Soldering Profile and Peak Temperature	Wave Flow: 260°C (1.5 mm from case), 10s, max.

Physical Specifications	
Case Material	Non-conductive Black Plastic (UL94V-0 rated) –
Pin Material	0.5mm Alloy42 Solder-coated
Potting Material	Epoxy (UL94V-0 rated)
Weight	2.0g
Case Dimensions	0.46" x 0.29" x 0.40"

EMC Specifications	
Radiated / Conducted Emissions	EN55032 Class B see EMI Filter
ESD	IEC 61000-4-2 Perf.Criteria A
Rad. RF	IEC 61000-4-3 Perf.Criteria A
EFT	IEC 61000-4-4 Perf.Criteria A
Surge	IEC 61000-4-5 Perf.Criteria A
Cond. RF	IEC 61000-4-6 Perf.Criteria A
PFMF	IEC 61000-4-8 Perf.Criteria A

<sup>1)</sup> These are stress ratings; exposure of devices to any of these conditions may adversely affect long-term reliability. All specifications typical at T<sub>A</sub> = 25 °C, nominal input voltage and full load, unless otherwise specified.

The information and specification contained in this data sheet are believed to be correct at time of publication. However RSG accepts no responsibility for consequences arising from printing errors or inaccuracies. **Specifications are subject to change without notice.**

## Number structure RSVR Series

RSVR	-	78	X	yy	(v2)
Name / package	Compatibility	Usage / Amps	Voltage out		
RSVR = SIL3	78 = LM78xx	M = Mid-Amp (0.5 A) F = Full-Amp (1.0 A) W = Wide-Input (0.5 A)	00 = 1.5 V 01 = 1.8 V 02 = 2.5 V ...	15 = 15 V	

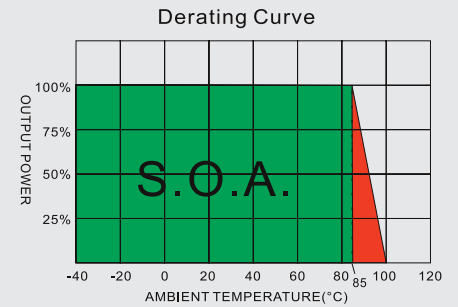

## Model Selection Guide

Model Number	Input Voltage Range (V DC)	Input Current No-Load (mA, max.)	Full Load (mA, typ.)		Output Voltage (V DC)	Output Current		Efficiency		Capacitor Load @FL (µF, max.)
			@Min. Vin	@Max. Vin		Min. Load (mA)	Full Load (mA)	Full Load (% , typ.)		
								@Min. Vin	@Max. Vin	
RSVR-78M00	4.75 - 30	8	202	38	1.5	50	500	78	65	220
RSVR-78M01	4.75 - 34	8	231	38	1.8	50	500	82	70	220
RSVR-78M02	4.75 - 34	8	302	48	2.5	50	500	87	76	220
RSVR-78M03	4.75 - 34	8	381	60	3.3	50	500	91	81	220
RSVR-78M05	6.5 - 34	8	409	86	5.0	50	500	94	85	220
RSVR-78M06	8 - 34	8	427	1 08	6.5	50	500	95	88	220
RSVR-78M07	9 - 34	8	421	1 18	7.2	50	500	95	89	220
RSVR-78M09	11 - 34	8	426	1 44	9.0	50	500	96	92	220
RSVR-78M12	15 - 34	8	412	1 88	12	50	500	97	94	220
RSVR-78M15	18 - 34	8	430	2 32	15	50	500	97	95	220

## EMI Countermeasures

Input filter components (C1, C2, L) are used to help meet conducted emissions requirement for the module. These components should be mounted as close as possible to the module; and all leads should be minimized to decrease radiated noise. An external filter capacitor is required if the module has to meet IEC61000-4-4.

Suggested filter capacitor: Nippon chemi-con KY series, 220 µF/100 V.

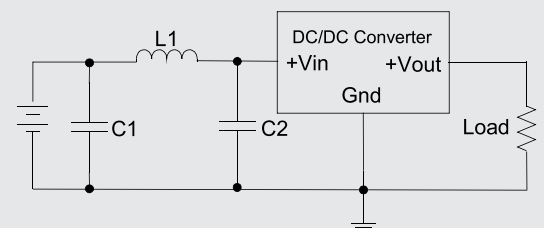

	C1	L1	C2
RSVR-78Myy	470 µF, 35 V	6.4 µH	470 µF, 35 V

## Standard Application Circuit

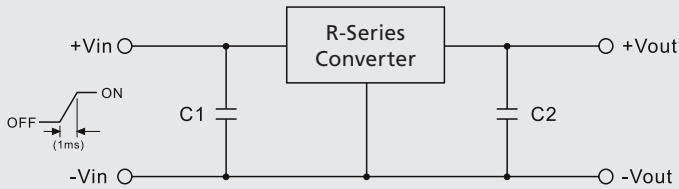

1. To protect the converter during power-up, use soft start Vin and C1 = 47  $\mu$ F
2. C2 = 100  $\mu$ F (Optional)

## Test Configurations

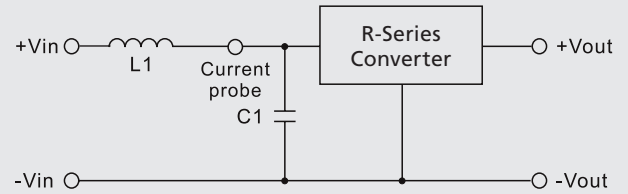

Input reflected ripple current is measured through a source inductor L1 (12  $\mu$ H) and a source capacitor C1 = 47  $\mu$ F at nominal input and full load.

## Application Examples

**High efficiency, isolated, dual unregulated outputs, one economic way to build up isolated dual output**

- Isolated dual outputs
- Wide input range 4.75 to 34 V
- C1: Optional
- C2: Required (further decoupling filtering may be necessary between the two converters)

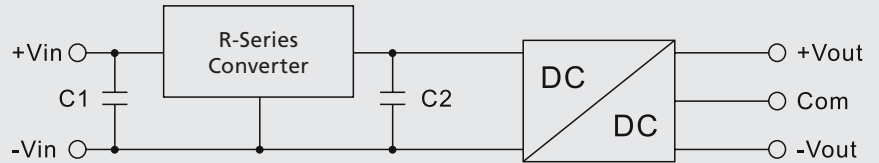

**Isolated (up to 6 KV), wide input range regulated output**

- High isolation voltage
- Improved loading / line regulation
- Wide input voltage range
- Point-of-load Architecture
- C1: Required (further decoupling filtering may be necessary between the two converters)
- C2: Optional

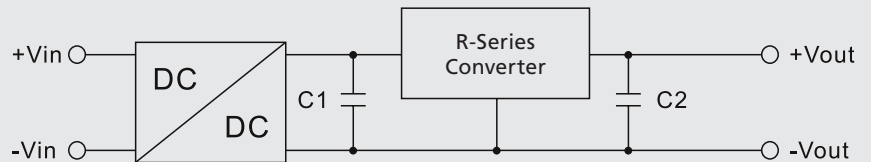

## Mechanical Specifications

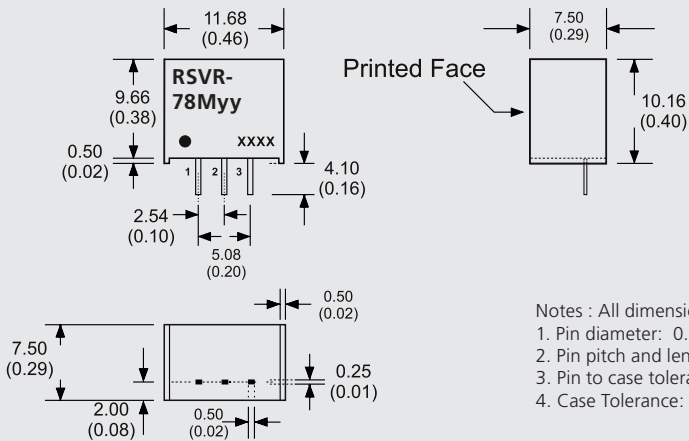

Pin Connections	
Pin Number	Single
1	+V Input
2	GND
3	+V Output

Notes : All dimensions are typical in millimeters ( inches ).

1. Pin diameter: 0.5 $\pm$ 0.05 ( 0.02 $\pm$ 0.002 )
2. Pin pitch and length tolerance:  $\pm$ 0.35 (  $\pm$ 0.014 )
3. Pin to case tolerance:  $\pm$ 0.5 (  $\pm$ 0.02 )
4. Case Tolerance:  $\pm$ 0.5 (  $\pm$ 0.02 )

## Notes

Ripple/Noise measured with 20 MHz bandwidth. Load condition : 10% ~ 100%, output noise arise when load is under 10 % .  
Tested by minimal Vin and constant resistive load.

Measured Input reflected ripple current with a simulated source inductance of 12  $\mu$ H.

Input filter components (C1, C2, L) are used to help meet conducted emissions requirement for the module. These components should be mounted as close as possible to the module; and all leads should be minimized to decrease radiated noise.

An external filter capacitor is required if the module has to meet IEC61000-4-4. Suggested filter capacitor: Nippon chemi-con KY series, 220  $\mu$ F/100 V.

Do not operate the unit(s) exceeding the absolute maximum rating, over rating causes damage to the units.

Operation under no-load conditions will not damage these devices, however they may not meet all listed specifications.